

Vip
2.10

AMPLIACIÓN DE COLECCIÓN

XILEWA
M O B I L I A R I O

Vip
2.0



REFERENCIA	DESCRIPCIÓN	MEDIDAS	TARIFA B
VIP1031	MÓDULO EXPOSITOR 2/P + 2 HUECOS	105 x 150 x 41	2,59
VIP1026	MÓDULO TV 150 2/P Y 1/C	150 x 63 x 41	1,98
VIP1012D	VITRINA DERECHA 2/P Y 1/C	60 x 208 x 41	2,61
VIP1002	ESTANTE PARED 130 C/PELICANOS	130 x 7 x 20	0,40
TOTAL COMPOSICIÓN MODULAR			7,58
VIP2020	APARADOR 4/P Y 4/C	190 x 96 x 42	2,59
TOTAL SALÓN COMPLETO			10,17

Vip
2.0



REFERENCIA	DESCRIPCIÓN	MEDIDAS	TARIFA B
VIP3038	CABECERO NIMES 180 T/PUZLE B-40	190 x 161 x 8	3,16
VIP3003D	MESITA 3/C DERECHA	50 x 61 x 41	0,87
VIP3003I	MESITA 3/C IZQUIERDA	50 x 61 x 41	0,87
VIP3007	XINFONIER 7/C	70 x 120 x 41	1,98
VIP3009	ESPEJO VESTIDOR	70 x 180 x 2,5	0,97
TOTAL COMPOSICIÓN DORMITORIO			7,85
VIP3050	ARMARIO 2/P CORREDERA PLAFONES	205 x 240 x 62	8,44
TOTAL DORMITORIO COMPLETO			16,29

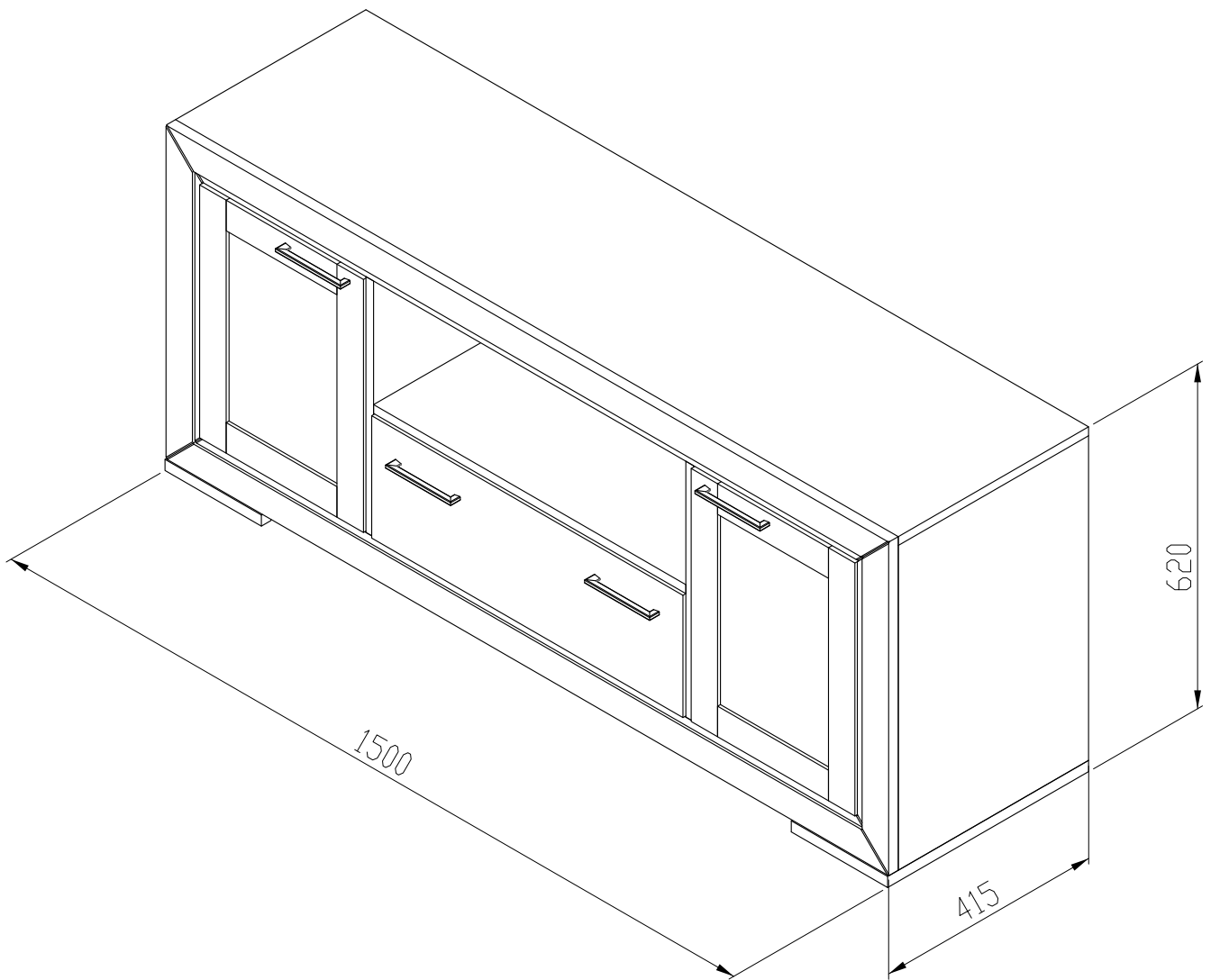

Módulo TV 150 2 Puertas 2 Cajones		Colección VIP 2.0
Escala 1:10	Acotación general 3D	Plano nº 1
Xilema Mobiliario S.L.		13/06/2016

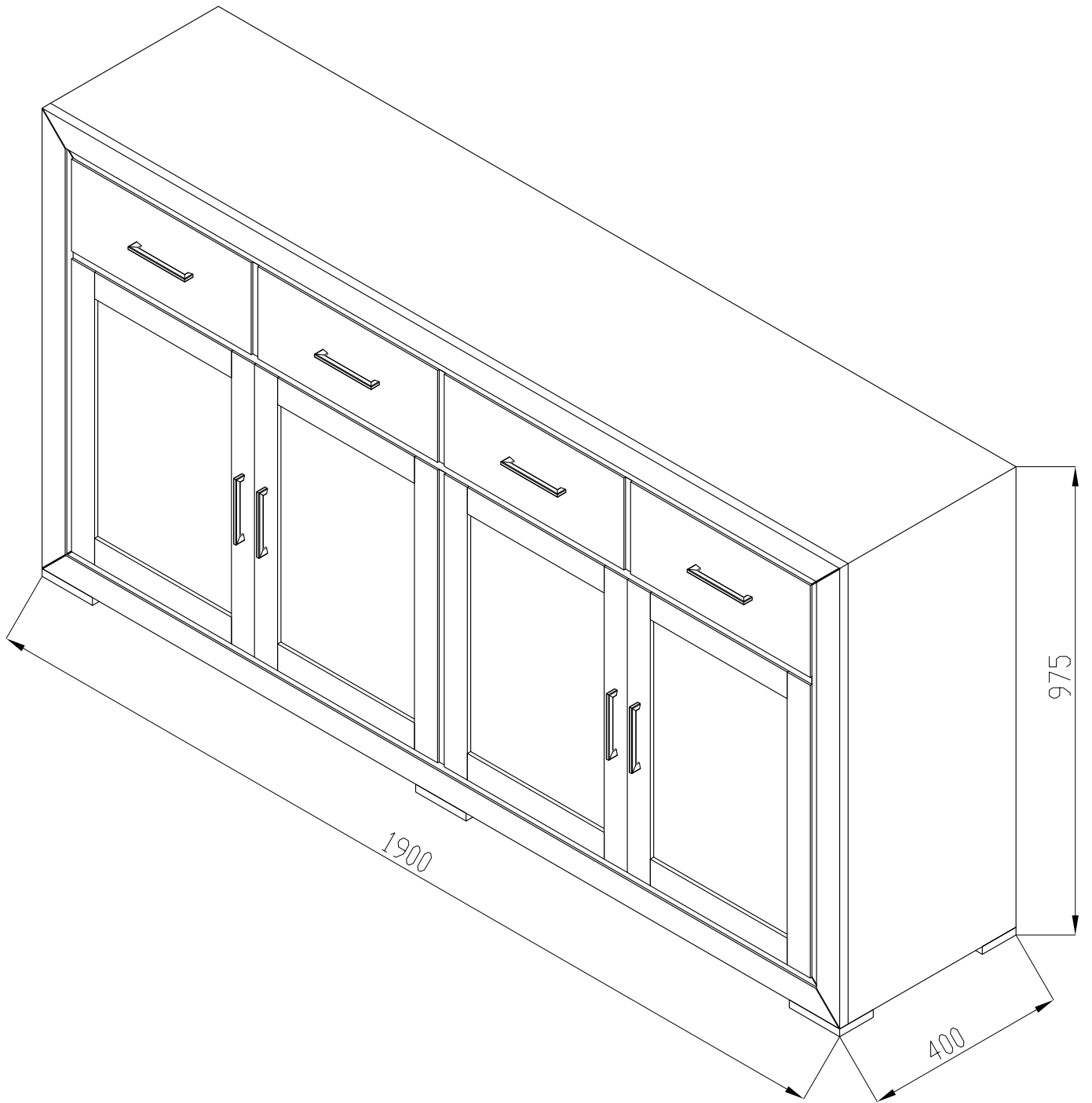

Aparador 190		Colección VIP 2.0	
Escala 1:10	Acotación general 3D		Plano nº 2
Xilema Mobiliario S.L.		13/06/2016	

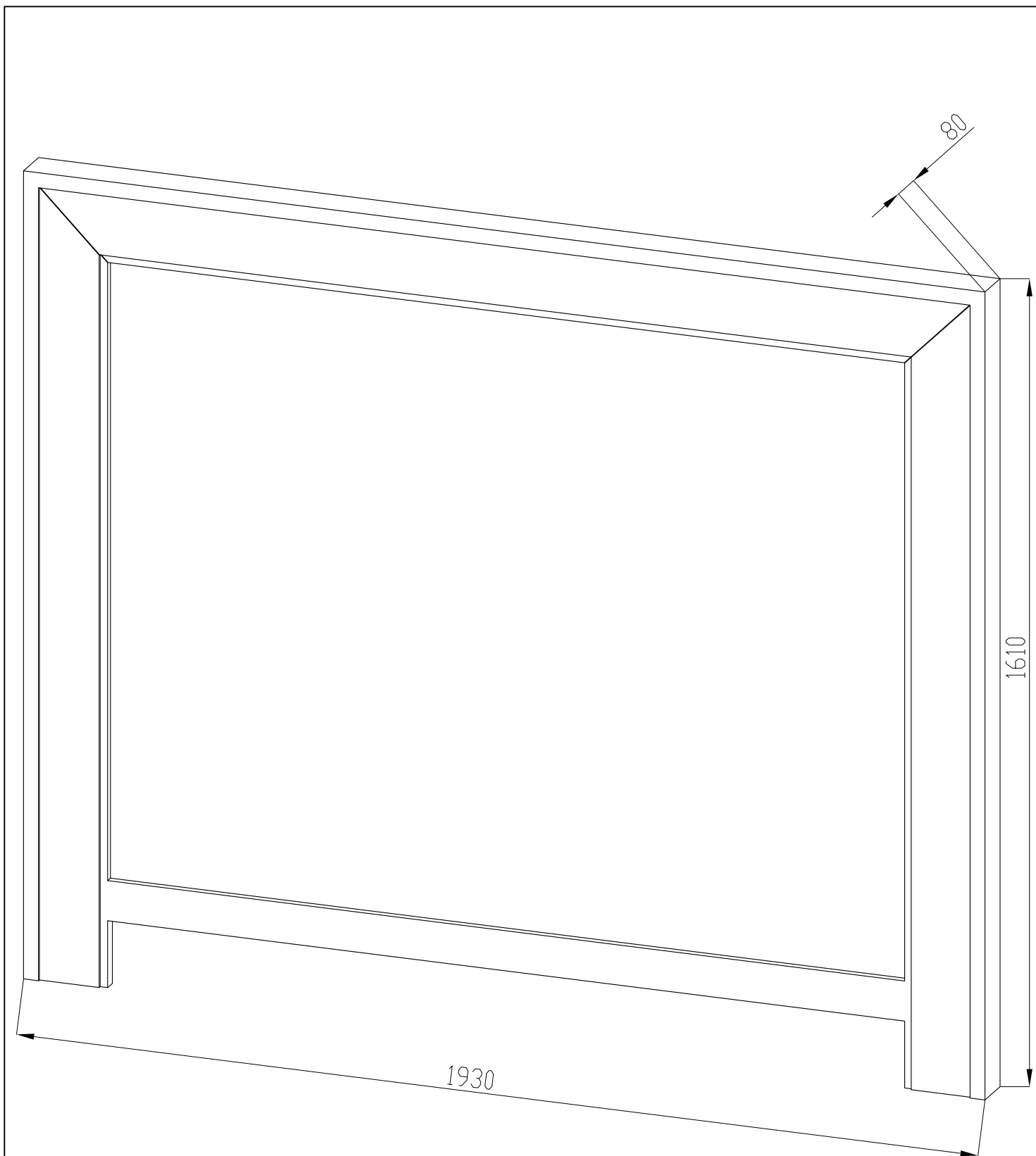

Cabecero Nimes para somier de 180		Colección VIP 2.0	
Escala 1:10	Acotación general 3D		Plano nº 3
Xilema Mobiliario S.L.		13/06/2016	

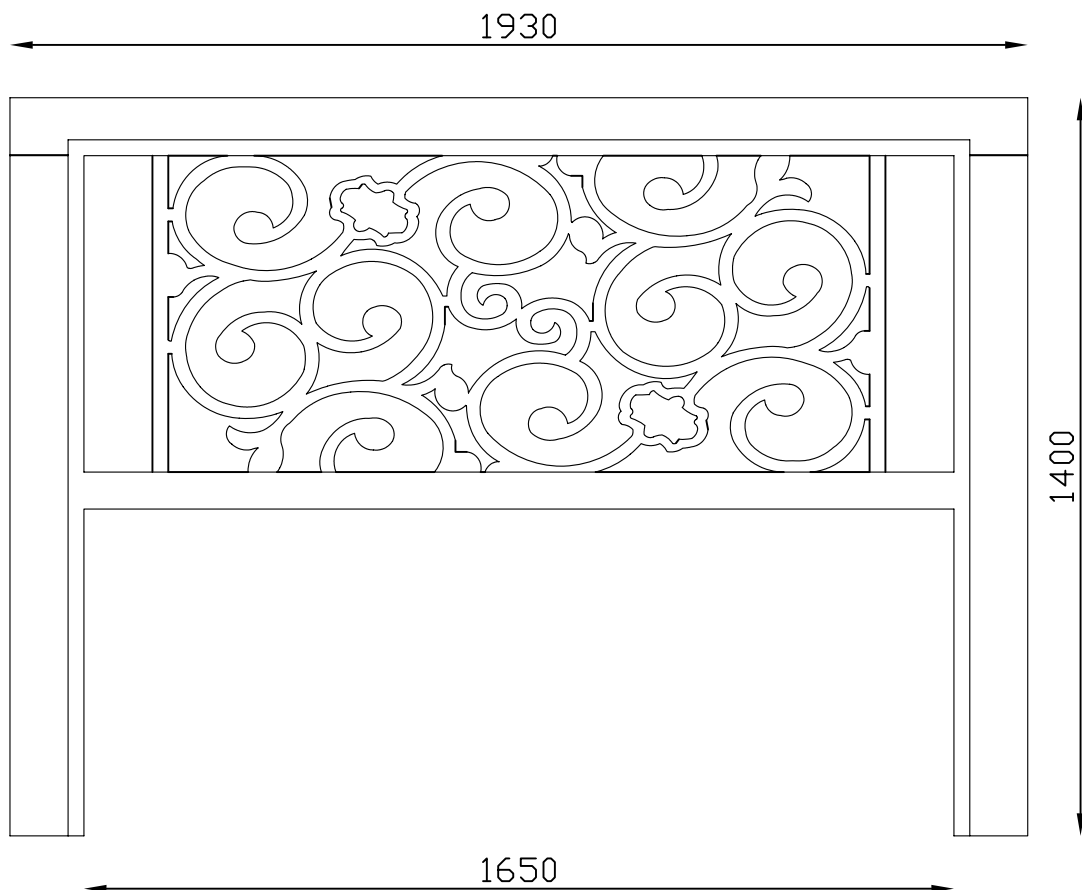

Cabecero VIP con filigrana para somier de 180		Colección VIP 2.0
Escala 1:15	Acotación en alzado	Plano nº 4
Xilema Mobiliario S.L.		13/06/2016

REFERENCIA	CONCEPTO	ALTO	ANCHO	FONDO	TARIFA A	TARIFA B
VIP1025	Mód. TV 150 2P 2C	62	150	41.5	2.03	2.17
VIP1026	Mód. TV 150 2P 1C	62	150	41.5	1.87	1.98
VIP1027	Mód. TV 150 2P 2H	62	150	41.5	1.78	1.89
VIP2020	Aparador 4P 4C	96.6	190	42	3.36	3.60
VIP3038	Cabecero Nimes 180 Tap. Puzle	161	193	8	2.96	3.16
VIP3039	Cabecero Nimes 180 Madera	161	193	8	2.90	3.11
VIP3040	Cabecero VIP 180 Tap. Capitoné	161	193	3	2.95	3.15
VIP3041	Cabecero VIP 180 Tap. Puzle	143	193	3	2.56	2.73
VIP3005	Cómoda 5 cajones	100	120	41	2,35	2,54



XILEMA MOBILIARIO, S.L.
Ctra. Córdoba / Málaga, N-331 km 78,600
Apto. Correos, 471
14900 Lucena (Córdoba)
Teléfono: 957 51 54 16 / 957 50 89 24
Fax: 957 51 12 06

e-mail: pedidos@xilemamobiliario.com
www.xilemamobiliario.com